

WF-9500LiS Series Power Centers

WF-9540LiS | WF-9560LiS | WF-9580LiS

(The Power Center model number is located on the door assembly label)



THE HEARTBEAT OF TODAY'S RVs

Distributed in the U.S.A. and Canada by
ARTERRA DISTRIBUTION

(877) 294-8997

Warranty: warranty@wfcoelectronics.com

Fax (574) 294-8698

www.wfcoelectronics.com



EXPERT PRODUCT SUPPORT

Power PROs Technical Support
(877) 294-8997

TABLE OF CONTENTS

SAFETY INFORMATION	3
GENERAL INFORMATION	
Reverse Battery Protection	3
Blown Fuse Indicators	4
DC Bulk Mode Indicator	4
Lithium Switch & Indicator	5
Automatic Cooling Fan	5
AC Voltage Indicators	5
Over-Temperature Protection	6
Electronic Current Limiting	6
Short Circuit Protection	6
CIRCUIT PROTECTION	
DC Fuses	6
AC Circuit Breakers	6
OPERATIONAL FEATURES - LEAD ACID	
3-Stage Smart Charging	8
Absorption Mode	8
Bulk Mode	9
Float Mode	9
OPERATIONAL FEATURES - LITHIUM	
2-Stage Smart Charging	9
Absorption Mode	10
Bulk Mode	10
TROUBLESHOOTING INSTRUCTIONS	
Converter Output Voltage	11
Reverse Polarity Fuses	11
Troubleshooting Flow Chart	11
GENERAL COMPLIANCE INFORMATION	
Agency Listings	12
INSTALLATION INSTRUCTIONS	
Mounting the Enclosure	12
Wiring the AC Breakers	12
Wiring the DC Fuse Board	13
SPECIFICATIONS	15
WARRANTY INFORMATION	16





⚠ WARNING
RISK OF ELECTRICAL SHOCK Disconnect or isolate all power supplies before making electrical connections. More than one disconnection or isolation may be required to completely de-energize equipment. Contact with components carrying hazardous voltage can cause electric shock and may result in severe personal injury or death.
NOTICE
All wiring must conform to local, national, and regional codes and regulations. Use copper conductors only for all wire connections. Do not exceed the electrical ratings for the WF-9500LiS Series Converter/Charger or the equipment connected to it. Failure to follow these precautions may cause equipment failure and/or electrical shock which could result in severe personal injury or death.
⚠ CAUTION
EQUIPMENT SERVICING This product should be installed by an experienced certified technician. CAUTION and care must be taken when servicing this equipment. To prevent severe shock or electrocution, consult your servicing dealer.
⚠ WARNING
SPARK HAZZARD This unit employs components that can produce arcs or sparks. To prevent fire or explosion, do not install in compartments containing batteries or flammable materials (LP gas). This product is NOT ignition protected.
⚠ CAUTION
DO NOT OBSTRUCT VENTILLATION To prevent fire, do not cover or obstruct front cover ventilation openings as overheating may result. This series is a zero-clearance design and as such, the only means of ventilation is through the front cover openings.
⚠ WARNING
BATTERY SYSTEM Use converter only on appropriate battery systems. Other usage may cause personal injury and damage. Follow battery maintenance procedures. Consult all battery manufacturer's recommendations for additional safety information before use.

GENERAL INFORMATION

WF-9500LiS Series Safety Features

Reverse Battery Protection

The WF-9500LiS Series Power Centers will charge the 12-volt House battery if installed. A battery does not have to be installed for WF-9500LiS Series Power Center converter operation. When a battery is installed, two reverse polarity fuses are installed to protect the converter circuitry. The fuses are located along the bottom edge of the DC fuse board near the VCC+ lug (refer to Figure 1 below). This feature prevents permanent damage to the converter from a battery connected into the circuit backwards. Blown polarity fuses are indicated by an illuminated Red LED near the lugs. In addition to protecting the converter section, the reverse polarity fuses are the main connection between the converter and the DC fuse board.



The fuse values and quantity vary depending on which WF-9500LiS Series Power Center you have. Refer to the table below.

- WF-9540LiS – 25A (2)
- WF-9560LiS – 35A (2)
- WF-9580LiS – 30A (3)

Blown Fuse Indicators on DC Fuse Board

The DC Fuse Board has individual blown fuse indicators as standard equipment. Each of the 17 DC fuse circuits contain a Red LED to indicate a blown fuse. If one of the circuits draws more current than the rating of the fuse, the fuse will blow. When this occurs, the Red LED for that circuit will illuminate. Replace the blown fuse with a known good fuse of the same rating. **NOTE:** If the replacement fuse blows again, check that circuit for a short or an overload condition.

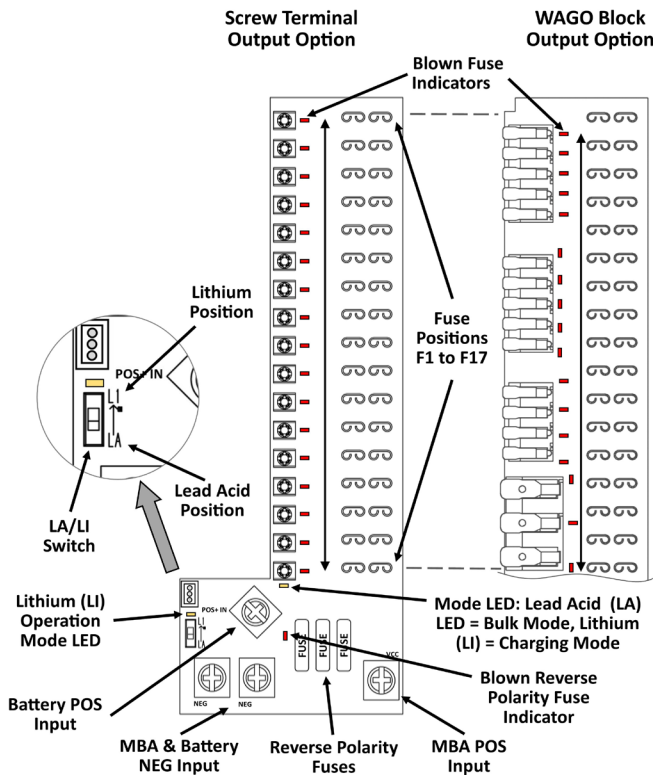

Figure 1

DC Bulk Mode Indicator

Anytime the converter goes into Bulk Mode, 14.4 VDC, the amber LED in the middle of the fuse board comes “on”. Anytime the converter is in the Absorption or Float mode the LED light will be “off”. When the converter is on battery only, this amber LED will also be “on”.

Lithium Switch & Indicator

When the switch is set to the Lithium mode, the amber LED at the top of the switch will be “on” indicating LI (Lithium). That light will remain “on” all the time the unit switch is in Lithium mode.

Automatic Cooling Fan

The cooling fan in the WF-9500LiS Series Power Center is incremental and is controlled by the current drawn out of the converter to the applied load. The on-board microprocessor increases fan speed as the total load increases, and decreases fan speed as the load decreases. Unlike traditional temperature-controlled fans, the load-controlled fan provides better component cooling by avoiding temperature spikes which can lead to premature component failure.

AC Voltage Input Indicators

The WF-9500LiS Series Power Centers have built-in indication of the incoming AC voltage. Three LEDs give at-a-glance status of Low, Normal or High voltage (see Figure 2 below). If the incoming voltage is within the normal operating range of 105 to 130 VAC, the Green LED will be illuminated. However, if the incoming voltage is less than 105 VAC, the Amber LED will illuminate. If the incoming voltage is greater than 130 VAC, the Red LED will illuminate. If either the Red or Yellow LED is illuminated, shut down the WF-9500LiS Series Power Center and investigate the cause of the problem.

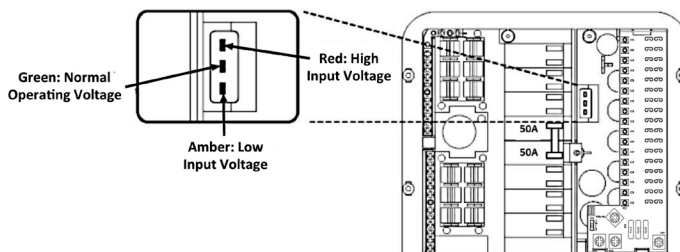

Figure 2



Over-Temperature Protection

If the internal temperature of the converter exceeds a critical point, it will shut down. This protects the unit from excessive heat that may damage sensitive components. The unit will restart once the temperature inside has dropped.

Electronic Current Limiting

In the event that the output current exceeds the maximum rating for the WF-9500LiS Series Power Center, the output current will remain constant but the output voltage will begin to drop. If this occurs, the unit will recover once loads are reduced.

Short-Circuit Protection

Should a short circuit occur in the RV, the WF-9500LiS Series Power Center will drop the voltage output to zero volts. If the short-circuit condition is removed and no other fault conditions are detected, the converter will resume normal operation. However, short-circuit conditions are **dangerous**, and the RV will require inspection by a qualified service technician.

CIRCUIT PROTECTION

WF-9500LiS Series Power Center Fuses and Breakers

DC Fuses (12 Volts)

The DC fuse board has spaces for seventeen (17) DC circuits. This includes three (3) 30 Amp circuits which may be used for any load requiring up to 30 Amps of current draw (Example: Slide-Outs). These three (3) circuits have a maximum rating of 30 Amps. The remaining fourteen (14) circuits have a maximum 20 Amp rating. The circuit fuses and the Reverse Battery Protection fuses should be replaced with ATC or ATO automotive type fuses such as:

- Littelfuse type 257
- Bussmann type ATC

AC Circuit Breakers (120/240 Volts)

The AC Breaker side of the WF-9500LiS Series Power Center is located on the upper left side. The WF-9500LiS Series Power Center accepts standard residential breakers. A total of fourteen (14) breakers can be installed: two (2) 50 Amp Main breaker and up to a maximum of twelve (12) AC Branch circuits when using duplex breakers. A list of factory tested and approved breakers follows.

UL-Listed Main Circuit Breakers, rated for 30/50 Amp, 120/240 VAC

The following breakers have been factory tested and approved for use as 50 Amp Main breakers in the WF-9500LiS Series Power Centers:

Manufacturer	Model/Cat. No./Type
Eaton	Type BR
ITE/Siemens	Type QP or QT
Square D	Type HOM
Murray	Type MP or MH
General Electric	Type THQL

UL-Listed Branch Circuit Breakers, Rated for 120 V, Maximum 20 A



The following breakers have been factory tested and approved for use as Branch Breakers in the WF-9500LiS Series Power Centers:

Manufacturer	Model/Cat. No./Type
Eaton	Type BRD
ITE/Siemens	Type QP or QT
Square D	Type HOMT
Murray	Type MPT or MHT
General Electric	Type THQL

When replacing any of the installed circuit breakers, the replacement should be of the same manufacturer, type designation, and equal or greater interrupting rating, not to exceed 50 A. The “Short-Circuit-Current” rating for the breaker should be 10,000 Amps at 120/240 VAC.

Breaker Filler Plates: Model FP-01 or FP-01B (Black)

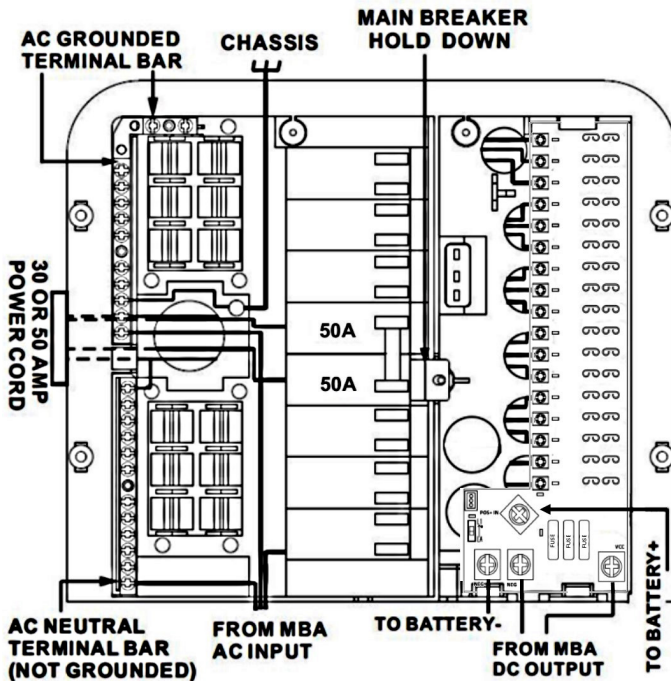

Figure 3

The WF-9500LiS Series converter-charger is equipped with a fuse board mounted switch which allows customers to change charging modes between lead-acid and lithium batteries. The different charging modes will be discussed in detail below beginning with lead-acid.



OPERATIONAL FEATURES

Lead Acid Operation Modes



Three-Stage Smart Charging

In order to maximize battery life, it is best to charge batteries slowly, keeping them topped off with a trickle-charge when the RV is not being used. The Three-Stage “smart” charger continuously measures the battery voltage and regulates the amount of charge using three modes of operation: Absorption, Bulk and Float modes.

Converter Modes of Operation

Understanding output voltages of a three stage converter.

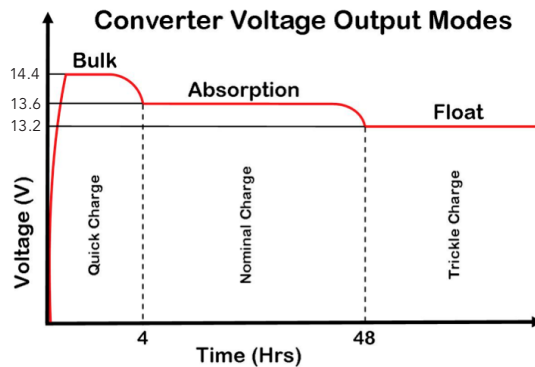

Figure 4

All WFCO power converters are automatic three-stage switching power supplies. The converter senses which mode it needs to be in by checking the RV system voltage.

Absorption Mode

This is the default or normal mode of operation. This mode provides an output of 13.6 VDC to the DC circuits in the RV. Because RVs today are designed with converters sized to provide ample DC output power for all DC loads in normal usage, an RV will rarely require anything other than Absorption Mode.

When a WF-9500LiS Power Center is connected to a battery and is operating in Absorption Mode, it is constantly charging that battery any time the converter output is greater than the voltage level of the battery. If the battery is at or near fully charged, the current draw from the converter to the battery may be very small. If the battery were to be fully discharged, the current draw from the converter to the battery may be quite high.

The WF-9500LiS Series Power Center can charge most properly-functioning, fully-discharged batteries (measured at 11.9 VDC) to a fully-charged level of 12.7 VDC in less than three hours when the converter output is in Absorption Mode (13.6 VDC) and a 20 Amp lighting load is connected. Please note that adding more DC loads to the circuits will decrease the amount of current available to charge the battery, and thus will increase the time required for the battery to reach a full charge. Batteries with damaged cells or sulfation will also require additional time to charge, and may never reach a full charge voltage.



Because of the relationship between voltage and amperage, once the converter reaches its maximum rated operating current level, any increase in the DC load will start to decrease the voltage output level. The converter will go into Bulk Mode when the measured output from the converter reaches approximately 12.5 VDC.

Bulk Mode

This mode is designed to charge a significantly discharged battery in a little less time than Absorption Mode. The microprocessor in WF-9500LiS Power Center continuously monitors the DC output voltage. When the microprocessor senses that the output voltage has dropped to a preset level, it will boost the output voltage from 13.6 VDC to approximately 14.4 VDC. The increased voltage will help the battery charge a little faster, while still providing power to the DC lighting and appliances in the RV.

In Bulk Mode, it may not be possible to observe the 14.4 VDC output because of the voltage-current relationship. To measure the 14.4 VDC output with a voltmeter, reduce some DC loads while monitoring the voltage at the converter output. As the DC loads are removed, the voltage will begin to climb until 14.4 VDC (nominal) is shown on the meter.

As the battery continues to charge, the current drawn by the battery will gradually decrease. WFCO Converters are designed to drop out of Bulk Mode when the total amperage draw from the converter reaches a preset point, indicating the battery is charged. **If the amperage draw stays above the preset point, the converter will stay in Bulk Mode for a maximum of four hours. These features have been implemented to protect and extend the life of the battery.**

Float Mode

This mode is the third stage of converter operation. It is designed to provide a trickle charge to the battery. If the converter observes no significant variations in current draw for approximately 44 continuous hours, it will drop the output of the converter from 13.6 VDC to 13.2 VDC. This lower voltage will keep the battery charged while the RV is not in use. This also helps preserve the life of the battery, while keeping it charged and ready for use. A small change in DC current, such as turning on a light or DC appliance, will cause the converter to exit Float Mode and return to the Absorption Mode. **Note:** While in the float mode, the converter will continue to supply a trickle charge to the battery. If the RV is in storage for thirty (30) days or more, it is good practice to check the battery and its fluid levels on a monthly basis.

NOTE: for a detailed explanation of the charging modes, please refer to our publication “*Theory of Operation*”, located under the Support heading on www.wfcoelectronics.com.

OPERATIONAL FEATURES

Lithium Converter Operation Modes

Two-Stage Smart Charging

The two-stage “smart” charger continuously measures the battery voltage output and regulates the amount of charge using two modes of operation: Bulk and Absorption mode.

Converter Modes of Operation

Understanding output voltages of a two-stage converter.

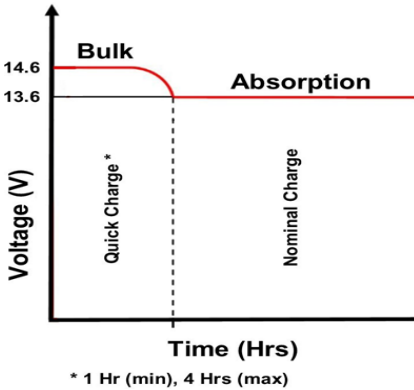

Figure 5

Bulk Mode:

This mode is designed with 2 purposes in mind. First, to quickly restore the energy back into the battery. Second, to ensure the lithium cells inside the battery remain balanced. This is accomplished by boosting the output voltage to 14.6 VDC and allowing the maximum current to flow as required by the loads.

The bulk mode stage could last anywhere from 1 to 4 hours based on the battery and load current which is being used. For a full battery, the bulk stage has a minimum time requirement of 1 hour, which allows the lithium cells inside the battery the time required to “balance.” For an empty battery, the bulk stage has a maximum time requirement of 4 hours. If your application requires longer than 4 hours (such as a larger battery bank > 200 Ahr), a simple cycling of power will reset the timers.

As the energy is restored into the battery, the DC system voltage will climb and the current from the converter will decrease. If the total amperage draw from the converter reaches a preset point (within the 1 to 4 hour timer), the converter is designed to drop out of bulk mode.

Absorption Mode:

This mode is designed with 1 purpose in mind. This purpose is to provide a safe operating voltage for all loads in the RV. This is accomplished by reducing (from bulk mode) the output voltage to 13.6 VDC and remaining at this voltage until the power is cycled to the converter. The absorption mode stage is the default or normal mode of operation, which has no timer associated with it. In this mode an output of 13.6 VDC is provided to the DC circuits in the RV. This voltage has a long-term history as the acceptable voltage for all loads in the RV, and should not place undue stress (nor reduce the longevity) of the lights and appliances in the RV. This is not to say that all loads will have an issue with a constant higher voltage; however, some loads may have an issue. Please refer to the individual manufacturer’s specifications for acceptable operating voltage range of the connected load.

⚠ WARNING

BATTERY SYSTEM

Use converter only on appropriate battery systems. Other usage may cause personal injury and damage. Follow battery maintenance procedures. Consult all battery manufacturer’s recommendations for additional safety information before use.

TROUBLESHOOTING INSTRUCTIONS

Troubleshooting the WF-9500LiS Series Power Center



Refer to the Troubleshooting Guide for the WF-9500LiS Series Power Center (Figure 6) on the next page.

Converter Output Voltage

Before checking the WF-9500LiS Series Power Center output voltage, disconnect the battery cables at the battery. Make sure the converter is plugged into an AC source (105-130 Volts). Check the converter output voltage at the battery with a voltmeter. Place the meter probes on the disconnected battery cables; place the **Positive** (red) meter probe on the + **Positive** red battery wire and place the **Negative** (black) meter probe on the - **Negative** black wire on the battery cable. Be sure you have good connections at the cables. With the switch in the Lead-Acid position, if the voltage reads 13.6 VDC (+/- 0.2) with no load, the converter is functioning properly. With the switch in the Lithium position, if the voltage reads 13.6 - 14.6 VDC (+/- 0.2) with no load, the converter is functioning properly. If the converter output voltage at the battery reads 0.0 VDC, or if the battery is not charging, check for an open inline fuse in the battery wire circuit. One may have been installed by the RV manufacturer. Also check for loose wiring connections.

Reverse-Polarity Fuses

If there is no DC output coming from the WF-9500LiS Series Power Center converter section, first check the reverse polarity fuses on the fuse board. Then, visually inspect the fuses for any breaks in the fuse element. If no breaks are found, use a continuity tester to check for continuity. If the reverse polarity fuses are blown, it means the RV battery was accidentally connected in reverse, either at the battery or at the converter. Investigate the connections and reconnect the cables properly. Replace the fuse with the same type and amperage rating as the original.

IMPORTANT: These fuses protect the converter from damage in the event that the RV battery is accidentally connected in reverse. A reversed battery connection, even if for only a second, will cause these fuses to blow. If the above checks have been made but the converter output still reads 0.0 VDC, the converter is not functioning properly.

Troubleshooting Guide for the WF- 9500LiS Series Power Center

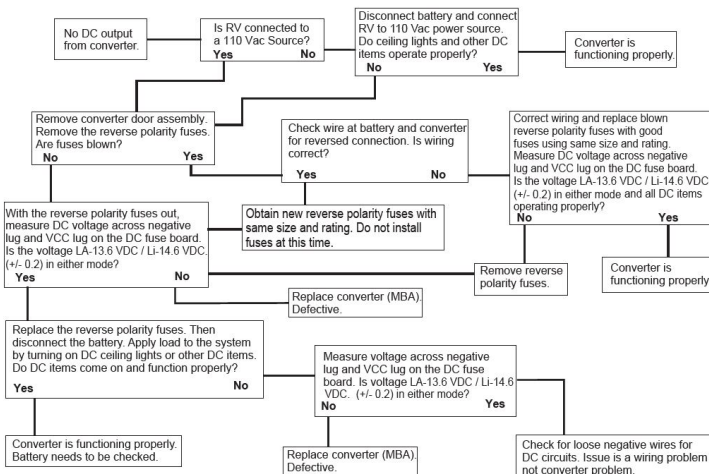

Figure 6



GENERAL COMPLIANCE INFORMATION

Agency Listings

UL

The WF-9500LiS Series Power Centers are UL-Listed, and cUL-Listed (Canadian).

FCC Compliance Class B

NOTE: This equipment has been tested and found to comply with the limits for a Class B digital device, pursuant to Part 15 of the FCC Rules. These limits are designed to provide reasonable protection against harmful interference when the equipment is operated in a commercial environment. This equipment generates, uses, and can radiate radio frequency energy, and if not installed and used in accordance with the instruction manual, may cause harmful interference to radio communications. Operation of this equipment in a residential area is likely to cause harmful interference in which case the user will be required to correct the interference at his own expense.

INSTALLATION INSTRUCTIONS

Installing the WF-9500LiS Series Power Center

Mounting the Enclosure

The WF-9500LiS Series Power Center enclosure should be mounted in an accessible area such as a wall or in the side of a cabinet. The front of the enclosure should not be obstructed to allow free air flow for the cooling fan. The enclosure will slide into a rough opening of 13.23 (in) H x 10.12 (in) W. The enclosure depth is 10.04 (in). After wiring is completed, the enclosure fastens to the wall or cabinet using 4 wood screws, not supplied.

Wiring the AC Breakers

**** Make sure no AC power is coming into the RV from either the Shore Power cord or an on-board generator.** Determine the proper size breakers for the loads the WF-9500LiS Series will be powering. You can use either single or duplex breakers, or a combination of both. We recommend that all the breakers used be of the same brand. When using duplex style circuit breakers, a total of fourteen (14) breakers can be mounted in the WF-9500LiS Series Power Center, two (2) Main breakers and twelve (12) Branch breakers. Refer to the tables on pages 5 and 6 for a selection of approved breakers. The Main breaker should be a 2-pole, 50 Amp type and should be installed in the center position (See Figure 7 on page 13). A hold down clip is provided to keep the breaker securely in place.

The 50 Amp power cord is routed through the largest knockout in the wiring compartment and secured with a listed strain relief clamp. A 50 Amp power cord has 4 leads; Black (HOT1), Red (HOT2), Neutral (White), and Ground (Green). The Black (HOT1) wire is connected to one side of the 2-pole 50 Amp Main breaker as shown in Figure 7 on page 13. The Red (HOT2) is connected to the other side. The White (Neutral) wire is connected to the Neutral Terminal bar at the bottom left of the wiring compartment. The Green (Ground) wire is connected to the Ground Terminal bar located at the top left of the compartment.



An 8AWG copper conductor shall be used to bond the WF-9500LiS Series Power Center to the vehicle frame.

Route the Romex leads for the Branch circuits through the Strain Reliefs in the back of the wiring compartment. In a similar fashion, connect the Black wire to the Branch breaker, and the White and Green wires to the appropriate Terminal bar.

The Black power wire for the converter has a pigtail connection. The metal pin is inserted in the Branch breaker designated for converter power. The end with the wire nut can be used to power another circuit if necessary. If not used, leave the wire nut installed and push the wire to the side. Make sure all terminals are torqued to the specifications listed on the back of the enclosure.

Wiring the DC Fuse Board

**** Make sure the house battery is disconnected and there is no AC Power connected to the system before beginning the DC wiring.** Determine what DC loads are to be connected to the fuse board and what position they will occupy. The 3 circuits closest to the battery lugs may be used for 30 Amp Max loads, and can accept a maximum 30 Amp ATO or ATC fuses installed. The remaining fourteen circuits are general purpose and can accept up to 20 Amp ATO or ATC fuses installed. Make sure the fuses are seated properly.

Depending on the WF-9500LiS Series Power Center model, there are 3 different methods of connecting the DC loads to the fuse board.

-S Models. These models have screw terminal connections. Strip approximately .25" of insulation from the load's wire and insert into the screw terminal. Tighten the terminal to the torque specified on the back of the enclosure.

-Q Models. These models have a male Quick Connect tab on the fuse board and mate with a female Quick Connect on the load wire. When installing this terminal, be sure the female terminal is fully seated on the fuse board.

-W Models. These models have a 12" wire for each circuit extending from the back of the enclosure. Strip approximately .50" insulation from the load's wire, twist the bare wire from the appropriate fuse position together with the load wire, and securely fasten with a suitably listed connector.

Connect the heavy wire (Red) coming from the battery to the **BAT+** lug located directly above the **VCC** lug on the fuse board. Make sure this lug is torqued properly.

As a last step, install a separate bus bar in a location behind the converter. Run a 6 AWG wire from the **NEG-** lug on the bottom left of the DC fuse board to this bus bar. Connect the battery negative wire to this bus bar along with all the negative DC load wires. Also, run a wire from the bus bar to chassis ground.

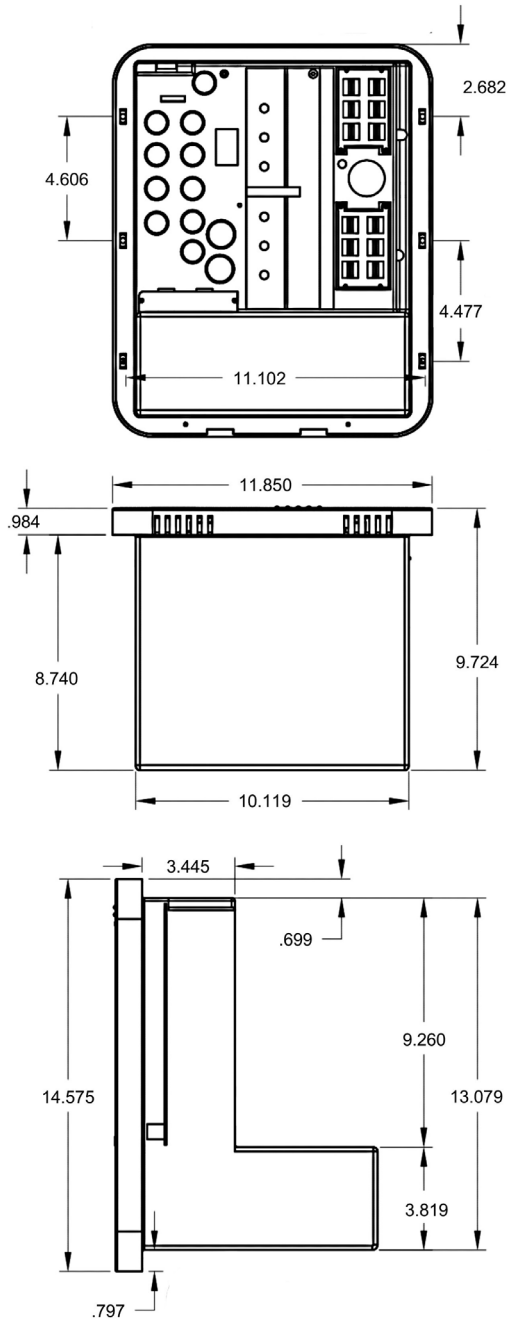

Figure 7



WF-9500LiS Power Center Specification			
Model No.	WF-9540LiS	WF-9560LiS	WF-9580LiS
	LA & AGM / Lithium ion		
Converter Input Power:			
Voltage:	105-130Vac		
Frequency:	60Hz		
Max. Input Current @105Vac	8A	12A	16A
Max Power	685 watt	1030 watt	1370 watt
Converter Output Power			
Continuous Power:	545 watt	820 watt	1090 watt
Rated DC Output Voltage	13.6V / 14.6V		
Rated DC Current	40A / 37A	60A / 55A	80A / 75A
Charging Control	Automatically controlled by microprocessor		
Charging Modes	3-stage Intelligent charge / 2-stage Intelligent charge		
Intelligent charge mode	Absorption, Bulk and Storage (Float) / Absorption, Bulk mode		
Battery Adaptability	LA & AGM / Lithium ion		
Absorption Charge Voltage	13.6V		
Bulk Charge Voltage: (4 Hrs)	14.6V		
Storage Charge Voltage	13.2V / None		
Regulation	± 1% accuracy against input or load changes		
Cooling Fan	Two speed according to the DC load amperage		
VA Efficiency:	> 80% (under 70% of load condition)		> 85% (under 70% of load condition)
Protection:			
Overload	Current-limiting & shut down; auto recovery upon normal load		
Short-circuit	Shut down & auto recovery upon return to normal load		
Over-temperature	Shut down & auto recovery upon return to normal load		
Battery Reverse Polarity	Protected by Fuse; same rated fuse replacement required		
AC Distribution			
Mains Rating	Max. 50A / 240VAC		
Breakers	50A Mains with up to 12 AC Branch Circuits		
Romex strain reliefs	12 position Romex strain reliefs for AC Branch Circuits		
DC Distribution Board			
Standard DC Output Loops	3 x 30 AMP ; 14 x 20 AMP max. each		
LED on Fuse Board:	Total 20 chip-LEDs; Red indicating fuse blown status of loops and reverse polarity; 1 x Amber LED indicating Bulk mode ON status; 1 x Amber LED indicating Battery type		
Visual Window:	Special design transparent window for reading LED status easily		
Mechanical:			
Zero Clearance:	Special design air cooling duct to avoid heat dissipation into confined space		
Dimension: W x H x D	11.85 x 14.57 x 9.72 inches (301 x 370 x 247 mm)		
Cutout Size: W x H	10.12 x 13.23 inches (257 x 336 mm)		
Weight:	3.5kg	3.6kg	4.2kg
Environmental Condition:	20 ~ 90% Non-condensing		
Safety	UL458 /UL67 certified; FCC Class B compliant		



CONSUMER LIMITED WARRANTY for WFCO Electronic Products

WFCO extends, to the original owner, a Two Year Limited Product Warranty. This warranty is in effect from the date of original purchase for a period of two (2) years. This limited warranty is extended specifically for and is limited to Recreational Vehicle application and is only valid within the continental United States, Alaska, Hawaii and the Provinces of Canada. WFCO warrants, to the owner, that its products are free from defects in material and workmanship under normal use and service based on its intended use and function. This warranty is limited to the repair or replacement, at WFCO's discretion, of any defective parts or defective assembly. Any implied warranties of merchantability or fitness for intended use are limited in duration unless applicable State Law provides otherwise. You may have other rights as specified by each individual state.

EXCLUSIONS and LIMITATIONS

The OEM warranty specifically does not apply to the following:

- Any WFCO product that has been repaired or altered by an unauthorized person;
- Any damage caused by misuse, faulty installation, testing, negligence, accident or any WFCO product installed in a commercial vehicle;
- Any WFCO product, whose serial number has been defaced, altered or removed;
- Any WFCO product, whose installation has not been in accordance to the WFCO written instructions;
- Any consequential damages arising from the loss of use of the product including but not limited to: inconvenience, loss of service, loss of revenue, loss or damage to personal property, cost of all services performed in removing or replacing the WFCO product. Specifications are subject to change without notice or obligation.
- Any WFCO Electronics products sold through unauthorized Internet sources (Example: eBay) will be excluded from all warranty coverage offered by Arterra Distribution / WFCO.

CONSUMER WARRANTY CLAIM PROCEDURE

Upon determination and validation by an authorized OEM dealer that a WFCO product has a defect, a Return Goods Authorization (RGA) number will be required before the product can be returned. The RGA number can be requested by completing the Warranty Information Fax Sheet and appropriate Troubleshooting Form found at www.wfcoelectronics.com. Once these forms have been completed, email the forms along with Proof of Purchase to warranty@wfcoelectronics.com or fax the three documents to the Warranty Department at (574) 294-8698. After receipt of the forms, an RGA number will be issued. This number shall appear on all correspondence with warranty service. Upon validation of the warranty, WFCO shall replace the product with a like product. The RGA number shall be placed on the outside of the carton used to return the product for ease of identification. Do not mark directly on the product. The product must be packaged properly to avoid further product damage which could cause a non-warrantable condition.

WARRANTY ASSISTANCE

The consumer may contact the selling Dealer or OEM for warranty assistance. The consumer may also contact Arterra Distribution at: (574) 294-8997 or Fax (574) 294-8698.





THE HEARTBEAT OF TODAY'S RVs

WFCOELECTRONICS.COM